

Shouldn't your shop look like a showroom and be a cash cow?

Making more money has never looked so good - Call us today for more information!

Challenger's EnviroLift® with AquaVantage™ inground lifts create a stunning, professional showroom-like appearance with open, aesthetically pleasing style. Since there are no columns or overhead bars, shops with AquaVantage™ lifts evoke cleanliness and professionalism and give technicians more space to work.

And since 11 inground lifts fit in the same space as 10 above ground lifts, you increase your revenue potential and bottom line by maximizing the number of service bays in your facility. With each service bay worth over \$200,000 in annual parts and service sales, more bays mean more productivity and more money.

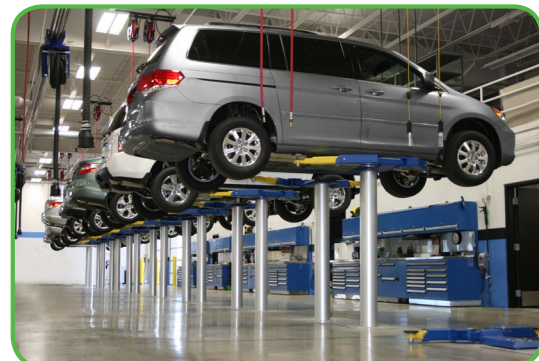

Features & Benefits:

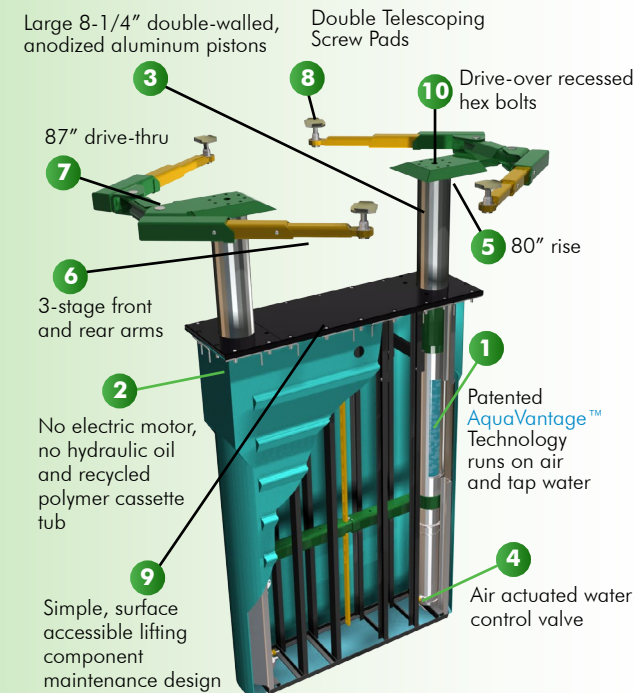

- 1 Providing an energy efficient lifting solution that is the leading environmentally friendly automotive lift on the market
- 2 Equals the only realGREEN™ sustainable earth friendly lift product
- 3 Provide stability, corrosion-resistance and a stunning showroom-like appearance
- 4 Allows for positive ascent and descent
- 5 Provides maximum head room for working underneath vehicles
- 6 Provide maximum arm retraction and reach to accommodate wide body sport cars and longer wheelbase vehicles
- 7 Accommodates wider vehicles, minimizes tire pinching and provides easy drive-on
- 8 Reach the widest range of vehicle pickup point heights reducing the need for adapters
- 9 Provides access to all lifting components without excavation, allowing routine maintenance at surface level
- 10 Minimize tire damage

Specifications	AV1020MP9	AV1020WV
Lifting Capacity	9000 lb. (4082kg)**	10000 lb. (4536kg)*
Stroke	73" (1854mm)	
A Rise Height	75 ³ / ₄ " (1924mm) ²	79 ¹ / ₈ " (2010mm) ¹
B Width Overall	31 ¹ / ₂ " / 79 ³ / ₄ " (800 / 2026mm)	97" (2464mm)
C Drive-Thru Clearance	N/A	87" (2210mm)
D Reach (Minimum)	W 31 ¹ / ₂ " x L 26 ¹ / ₂ " (800mm x 673mm)	19 ⁵ / ₈ " (498mm)
E Reach (Maximum)	W 79 ¹ / ₂ " x L 80" (2019mm x 2032mm)	42" (1067mm)
F Rubber Pad Adapter Minimum	2 ³ / ₄ " (70mm)	3 ⁷ / ₈ " (98mm) ³
G Rubber Pad Adapter Maximum	5 ³ / ₄ " (146mm)	6" (153mm) ³
Capacity (Per Arm/Pad)	2250 lb. (1021kg) (per pad)	2500 lb. (1134kg) (per arm)
Speed of Rise	Approx. 45 Seconds	
Operating Pressure (Air)	200 psi	200 psi
Recommended Ceiling Height	84" (2134mm) plus height of tallest vehicle	

* 10,000 lb. lifting capacity with 200 psi. ** 9,000 lb. lifting capacity with 200 psi. Beam lifting capacity is 9,000 lbs. 1 Rise height is measured with superstructure in highest position. 2 Rise height is measured with superstructure in highest position with rubber spotting block. 3 Specifications are listed without rubber pad, for measurements with rubber pad add 1/4" (6mm). † Optional frame engaging adapters (10314 or 10318) are REQUIRED when lifting vehicles with frame construction.

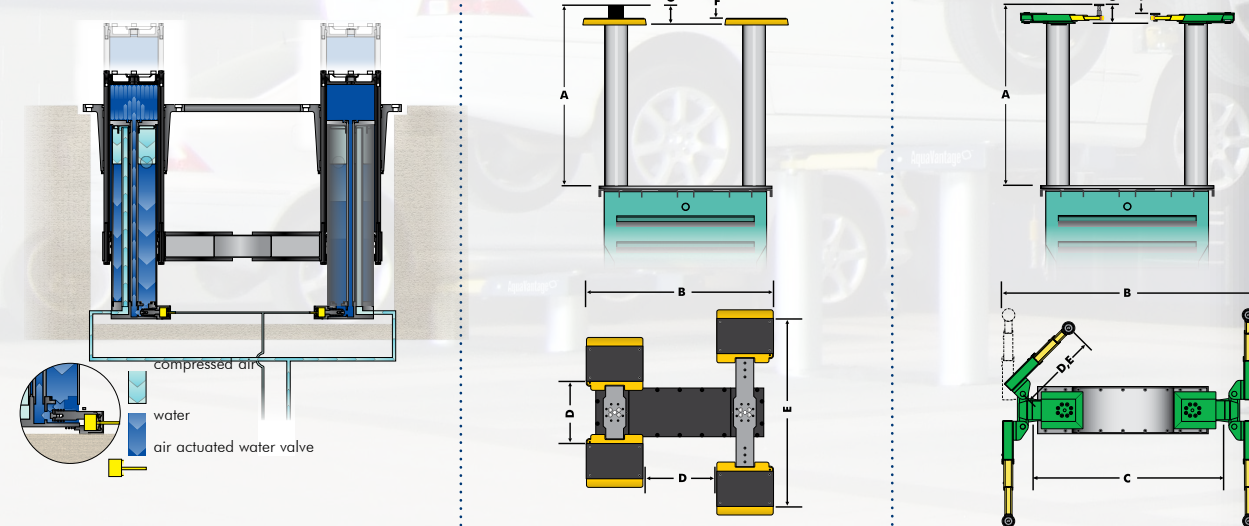

▲ Raising the lift

Compressed air is forced into the base of each cylinder, opening the air actuated water valves. This forces the water in the internal reservoir piston to flow into the larger lifting piston resulting in positive rise.

▼ Lowering the lift

Compressed air opens the air actuated water valves and the air in the internal reservoir piston is exhausted, allowing the water to travel from the lifting piston back to the internal reservoir piston.

For more information, contact your Authorized Challenger Lifts Distributor.



The Automotive Lift Institute (ALI) certifies that the AV1020WV described herein complies with the applicable provisions of the American National Standards ANSI/ALI ALCVT 2011 and is Third Party Validated by the ETL Testing Laboratory.

CHALLENGER LIFTS, INC.
200 Cabel Street
Louisville, Kentucky 40206

Phone Toll-Free: 800-648-5438
502-625-0700
Fax: 502-625-0711
E-mail: sales@challengerslifts.com

Challenger Lifts, Inc. reserves the right to make changes to specifications without notice and without making changes retroactive. Unloading, installation and water not included.



Model #: AV1020WV
AquaVantage™ Inground Lift
10,000 lb. lifting capacity*

AV1020 series

EnviroLift®
with AquaVantage™

realGREEN™
earth friendly product

CL Challenger Lifts



Green Benefits

Although traditional inground electric and oil auto lifts have become more environmentally friendly, these lifts still operate with electrical motors and hydraulic oil, ATF fluid, or bio-fluid.

Since AquaVantage runs on air and tap water, two of our most abundant and natural resources, there are no issues with federal, state, or local regulations should the fluids need to be discarded. You can rest assured you are making the right environmental decision.

And since it features such an innovative realGREEN™ design, functioning similar to the traditional low pressure high oil volume lifts of yesterday, without any oils or high pressure cylinders, AquaVantage showcases the best balance of safety, reliability, productivity and eco-friendly benefits.

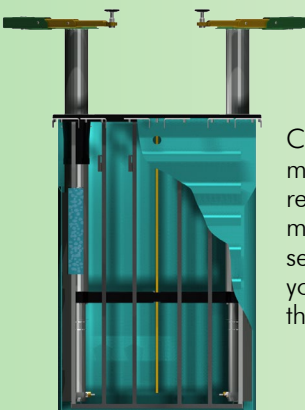
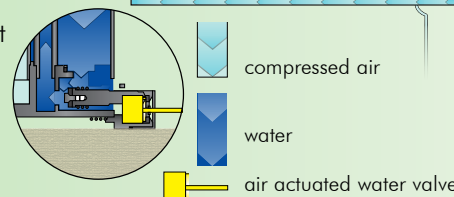
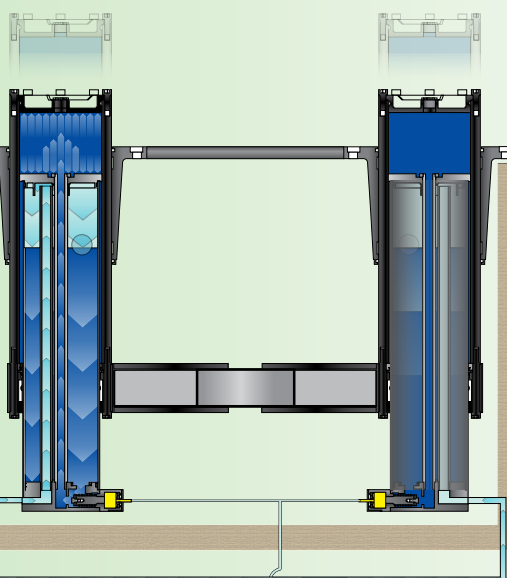

Containment is made up of 100% recycled polymer materials and is sealed to protect your investment and the environment.



- » No hydraulic oil or bio-fluid
- » No noisy electrical power motors with ATF or oil
- » No high pressure cylinders



Simply put, AquaVantage wears green better than any other automotive lift in the industry.

- » Minimal and recyclable packing materials to protect the environment
- » Fewer moving parts means less material to dispose at end of its life cycle
- » Steel components can be recycled at the end of its life cycle

The EnviroLift® with AquaVantage™ runs on compressed air and tap water instead of electric motors and oil, making it the cleanest and most environmentally friendly lift in the industry.



Raising the lift
Compressed air is forced into the base of each cylinder, opening the air actuated water valves. This forces the water in the internal reservoir piston to flow into the larger lifting piston, resulting in positive rise.

Lowering the lift
Compressed air opens the air actuated water valves and the air in the internal reservoir piston is exhausted, allowing the water to travel from the lifting piston back to the internal reservoir piston, resulting in descent.

environmental considerations

Interested in helping protect the environment? Looking to acquire LEED® certification for a new build or remodel? Our exclusive patented realGREEN™ lifting technology is more energy efficient than traditional electric / oil hydraulic lifts, making it a clear choice for green projects.



LEED® and the related logo is a trademark owned by the U.S. Green Building Council and is used with permission.

Unlike some green products, there's no compromise in performance and reliability. AquaVantage has a faster speed of ascent and rises taller and quieter than traditional electric/oil inground auto lifts.

Discover why AquaVantage lifts are the best automotive lifting solution -

Good for your Bottom Line & the Environment.

Precision Manufactured

Not only does AquaVantage meet strict ANSI industry standards, it's manufactured to the tightest of tolerances which provide these key benefits:

- » Repeatable superior quality
- » Cutting edge, state-of-the-art product
- » Reduced internal stress to extend the life of the lift



Service From Above

All lift components are within arm's reach making them service accessible by simply removing the cover plate. No digging to service the lift.

- Access to:
- » Lock release
 - » Air actuated water valve
 - » Control valve
 - » Air fitting
 - » Grease points



Large Double-Walled Anodized Aluminum Pistons

Large 8-1/4" anodized aluminum pistons inhibit contaminants and rust and feature an innovative double-walled design for improved strength, stability and rigidity. This provides a smooth, stable and repeatable lift each time.

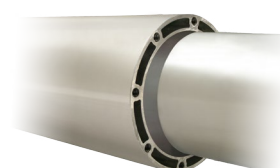

Redundant Safety System

Safety system with closed valve internal locking mechanism and mechanical locking ladder that engages every 3".

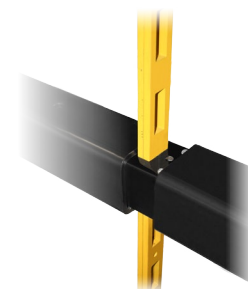

Smaller Footprint = More Money

11 inground lifts fit in the same space as 10 above ground lifts. With each service bay worth over \$200,000 in annual parts and service sales, more bays mean more money.



Taller Rise Height

The highest rise in the industry provides maximum comfort and head room for working underneath vehicles

- » 80" tall rise height
- » Full 73" stroke
- » Provides plenty of room for taller techs



Recessed Drive Over Bolts

Recessed hex bolts with plastic protectors eliminates tire damage and makes drive over seamless when loading the vehicle. Raised hex bolts can cause tire damage and hinder forward movement of the vehicle.

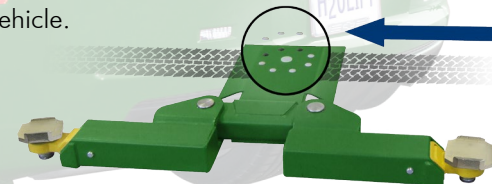

More Benefits

Take a Look - Overall Lower Cost of Ownership

The difference is clear as water. From new construction savings to the grand opening, to ongoing yearly savings to sustainability years to come, the AquaVantage lift has a lower cost of ownership.

New Construction Build Savings

- » No 25 amp dedicated electrical circuit for each lift at installation
- » No electrical conduit, copper wire, or electrical labor to install
- » Water is 450 times less expensive than hydraulic oil and bio-fluid costs 3 times as much as petroleum oil and is subject to separation and rancidity
- » No hydraulic hoses - air lines are factory furnished with each AquaVantage lift

Recurring Savings

- » No electrical motor - operates on shop equipment you already require (compressor)
- » Less grease, less labor - under normal use, requires only annual greasing while electric lifts require monthly greasing - a substantial savings over the life of the lift
- » Less moving parts = less replacement parts. No high pressure cylinders, electrical motor or switch buttons to replace
- » Quicker maintenance - Surface accessible service design provides quick access to all lift components in the containment

Power Control Configurations



Ergonomic Power Controls

Single handed, ergonomic power controls with pneumatic switching, integrated air pressure gauge and keyed lockout safety feature for convenience and simple, seamless operation.



Workbench Power Controls

Optional integrated workbench power control units mount behind manufacturer's benches, providing an unobtrusive, clean and organized look. Must be ordered with lift.

Lifting Point Configurations

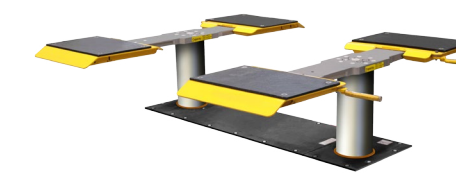

Drive-on fixed pad with 2-way directional adjustable sliders

Comes standard with (4) 4-1/8" multi-position rubber spotting blocks

Model#: AV1020AP
9,000 lb. capacity*



Optional Swing Arm Lifting Point Accessories

Part#: 10315 Stack Adapter Kit
Includes (4) 3" stack adapters, (2) 6" adapters and (2) organizer racks

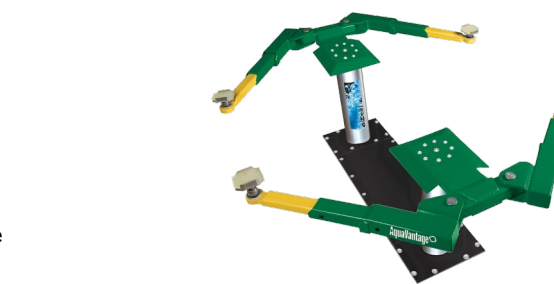
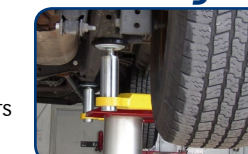

3-stage front and 3-stage rear swing arms with double telescoping screw and removable rubber pads

Model#: AV1020WV
10,000 lb. capacity*



*Part#: 10318 Frame Engaging Adapter Kit
Frame engaging adapters (set of 4)